



Mini AutoFeed-Retriever User Manual



072925

**Manufacturers of Quality
Sewer and Drain Cleaning
Equipment Since 1957**

www.MyTana.com

746 Selby Ave • St. Paul, MN 55104
fax: (651) 222-1739

(800) 328-8170

Factory Direct Customer Service
M-F 7am – 5pm CST
Competent • Polite • Clear

Installing the Mini Autofeed on to the M661

The Mini Autofeed-Retriever needs to be mounted on a hoop that connects to the M661.

The hoop frame is designed to be added or removed quickly and can be installed or removed with the Autofeed mounted- if desired.

The Autofeed can easily be removed from the hoop for changing reels of cable or for access to the revolving feed arm.

The hoop is available for purchase online at <https://mytana.com/product/m661-autofeed-hoops/>



Step 1

Install by placing hoop frame at an angle over the top front channel bar of the M661 frame, so that the top of hoop frame hooks into place.



Step 2

Pull out the plunger style lock pin on bottom right hand corner of hoop frame as you push front of hoop frame downward. Release pin when it lines up with locking hole that is drilled into the M661 frame.



Step 3

The Autofeed attaches to the hoop frame via the bracket mounted onto rear of the Autofeed. Slide this bracket into channel of the mounting bracket on the front of the hoop frame.



Step 4

Tighten thumb screw on the bottom of the hoop bracket to lock Autofeed in place.

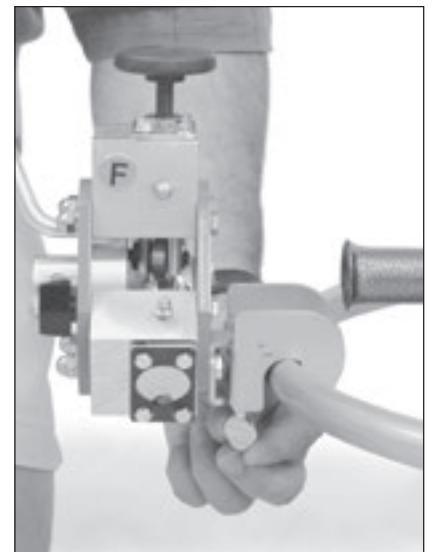

Spacers

The spacer plates at the bottom end of the lower two cylinders on the Autofeed determine the proper spacing to maximize the grip of the drive wheels on your cable. Normally, the correct spacing is preset for the cable you will be using. However, double-check to make sure that the spacing is correct, or adjust accordingly by using the chart. See schematic if adjustments are required.

Cable Size	Spacers Required
1/4"	1
5/16"	1
3/8"	2
1/2"	2

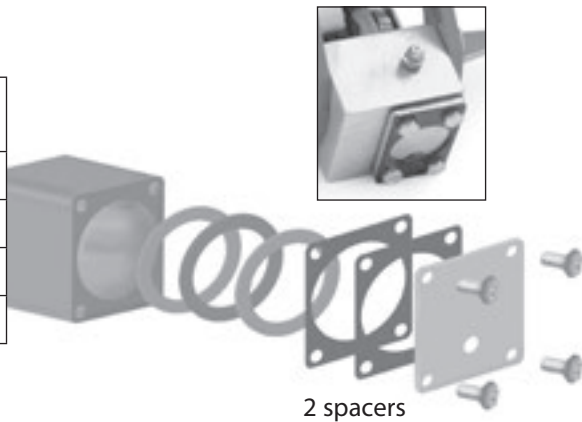

General Operation

NOTE: MyTana machines tend to push cable forward, out of the machine. For this reason, we recommend manually feeding the cable into sewer lines rather than using the Autofeed only to advance the cable.

Be sure to read the User Manual that came with your M661 before operating the machine with the Autofeed-Retriever.

1. Disengage Autofeed (by loosening screw knob on top cylinder)
2. Insert cable into pipe opening several feet **before turning on machine.**
Never insert a spinning blade into a sewer line!



If you choose to use the Autofeed for pushing cable into the sewer line, move the feed lever about 10 degrees toward the "F" and turn on your machine.

Turn the screw more knob on the top cylinder to the right until the cable starts to move forward. **DO NOT tighten the knob more than is required to move the cable forward.**



Push lever fully into the forward position. Proceed with caution, keeping in mind that it is essential that the cutting blade not be forced through an obstruction using the forward force of the Autofeed.

- ▶ Do not run cable fittings (couplings, splicers, cable ends) through a tightened down Autofeed, it can break feed wheels. Disengage the Autofeed (turn screw knob to the left), pull fittings through manually and then re-engage.

If the cable resists going forward or backward, then one of several things is occurring:

- You are hitting an obstruction. However, if torque does not start to build, you may be at an elbow or the blade may be hitting an offset or break in the sewer line. Apply some forward pressure manually to help you figure out what it is there.
- The Feed Wheels are worn and need replacing.
- There is debris hanging onto the end of cable and blade that is resisting retrieval. In this case manually help the Autofeed pull the cable back into the reel. Clear blade of debris and run cable through sewer line again to make sure all blockages are removed.

Obstructions

When your blade finds an obstruction it will usually stop the rotation of your cutting blade. If the blade does not release after several seconds of torque:

- Move the Autofeed lever to the "R" (reverse) position
- Read the instructions from your machine's User Manual for releasing a stuck blade

The most efficient cleaning is achieved by learning how to use torque build-up in your cable without over-torquing to the point of damaging cables or blades.

Finishing Up

When the obstruction is removed, place the Autofeed/Retriever fully in the "R" position until you hear the blade nearing the pipe opening. Disengage Autofeed (by turning screw knob to the left) shut off machine and pull the blade out of the pipe opening.

Helpful Tips

The following tips will add life to your cable, blades and Mini Autofeed-Retriever.

- Avoid turning down the screw knob on top cylinder of feed too tightly. Turn knob only as far as needed to move cable back and forth. Over tightening can:
 - cause excessive wear on cable and, if extreme pressure is applied can impede the proper rotation of the cable through the Autofeed
 - cause the cable to stack loosely into the reel when retrieving, rather than stacking the cable snugly against the outer walls as it should
 - break feed wheels
- Do not run cable fittings (i.e. couplings, splicers, cable ends) through a tightened down Autofeed, it can break feed wheels. Release the Autofeed, pull fittings through manually and then re-engage.

Bulb head / open hook cable

Cable that is expanded at the front (bulb head) or cable with an open-hook end may require larger openings through the feed wheels than the normal spacing of the wheels allow.

To accommodate this, a removable plastic wing nut is used with a mounting bolt on the bottom right cylinder of the Autofeed.

Remove the wing nut and bolt then swivel the cylinder downward. This creates a large enough opening so the wide head of the bulb head or open hook cable can slide through.

Once the larger head is through the feed, swivel the cylinder upward and replace mounting bolt and wing nut.

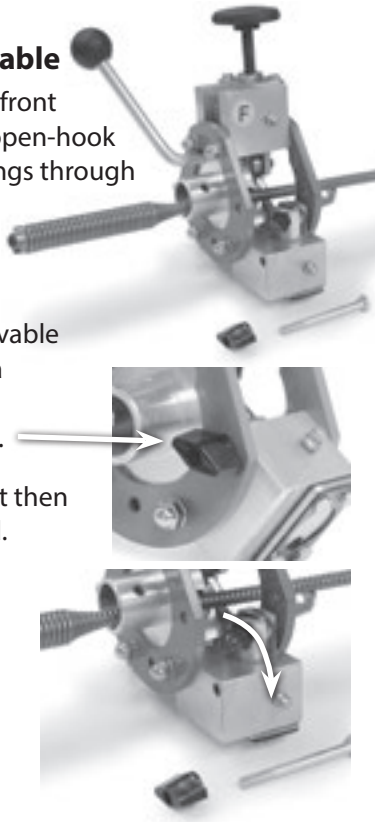

Routine Maintenance

- Watch for wear on drive wheels (bearings) and pins.
- Make sure drive pins stay in designated slots on movement disc.
- Remove debris (i.e. rags, string, hair) from cable before running through the Autofeed. This kind of debris can clog up the Autofeed wheels and movement parts rather quickly.
- If Autofeed is not to be used for a period of time, lubricate before storage

Lubrication

As with any mechanical device, proper care will maximize the life of your Mini Autofeed-Retriever. Keeping it clean and properly lubricated is essential.

The Feed unit has been greased at the factory. However, routinely continue to grease all housings equipped with zerks (grease fittings).

Remove front disc periodically, clean and lubricate. Free movement of the front disc is crucial to proper movement of cylinders and drive wheels.

Replacing Drive Wheels (also called Drive Bearings)

See parts breakdown on the insert for reference

1. Remove Autofeed from cable machine
2. Remove 6 acorn nuts / lockwashers from front panel
3. Remove front disc and movement assembly
4. Slip cylinder housing **Part MSF106** (whichever one that needs new drive wheel) from hex bolts
5. Remove piston **Part MSF107** from housing (it will lift out of housing)
6. Remove clip spring that holds drive pin
7. Carefully pull out drive pin **Part MSF111**
8. Remove spacers and drive wheels
9. Clean all parts in cleaning solvent before reversing procedure to install new drive wheel(s).

NOTE: It is a good idea to clean up the cylinder housing at the time that you change drive wheels. There is a thrust bearing with races at the bottom of each cylinder that needs to be cleaned periodically. These parts can be accessed by removing the spacer plates and end cap at the bottom of the housing.

