



M500 The Mini Workhorse

Our M500 Mini Workhorse is a professional grade, powered drain snake perfect for bathtubs, urinals and sinks and 1" to 2" lines.

Loaded with 50' of 1/4" cable, it weighs just 23 lbs.

- **Heavy duty drive train** has quiet operation and variable speed.
- **Rugged frame** allows for horizontal or vertical operation, and easy draining into a bucket.
- **Cone and funnel design** keeps the cable against the funnel wall to help prevent flipping.

The M500 is easy to maintain. Repairs can be made in the field or in your shop.



Shown equipped with 1/4" cable and optional elephant trunk guide

M500 At-a-glance

LINE SIZE 1" - 2"

MOTOR Electric

SPEED Variable,
up to 280 rpm

BASE WT 23 lbs (with cable)

All MyTana cable machines feature:

OPERATOR SAFETY features such as electrical protection

RUGGED FRAMES which emphasize ergonomics, portability, maneuverability, and stabilization during operation

QUIET OPERATION for residential use

CUSTOMIZABLE cable, fitting and reel styles, optional add-ons

Rugged Workhorses. Built to Last.

Made in the USA with factory-direct support.

www.MyTana.com ■ (800) 328-8170

M500 Specs

| SYSTEM OVERVIEW | |
|-----------------------|--|
| LINE SIZE | 1" - 2" |
| CUSTOMIZATION OPTIONS | Add cable Add Elephant Trunk guide |
| BASE: MOTOR | |
| TYPE | Electric, DC drive |
| DRIVE MECHANISM | Belt |
| CONTROL | Safety/master toggle switch Foot pedal – gives 2 handed control of cable Reverse switch for jams Cable guide (optional) |
| SAFETY | GFCI Watertight electrical |
| BASE: FRAME | |
| FRAME STYLE | Caddy, vertical or horizontal operation Rubber, anti-skid feet |
| FINISH | Aluminum, powder-coated |
| OPERATING WEIGHT | 23 lbs (with cable) |
| DIMENSIONS | 12.5" w x 17.5" d x 17" h |

| CABLE REEL AND DRUM | |
|-----------------------------------|--|
| CONSTRUCTION | Closed – polyethylene reel has drainage hole, contains splatter Has inner funnel (one piece construction) |
| RPM REEL | Variable, up to 280 rpm Change speed as you work |
| CABLE Optional with base purchase | |
| SIZE AND LENGTH | 1/4" x 50' |
| MATERIAL | Premium grade steel, precision-wound Rust resistant |
| CORE | Hollow core |
| FITTINGS | N/A – 1/4" cable has open hook end |

INCLUDES – Foot pedal, hose and switch

REQUIRED FOR OPERATION – Heavy duty extension cord

ADDITIONAL FEATURES

Motor – Variable speed

– Recessed power cord jack

Frame – Cone and funnel design to prevent cable flipping

– Fits in 5 gal bucket for drainage

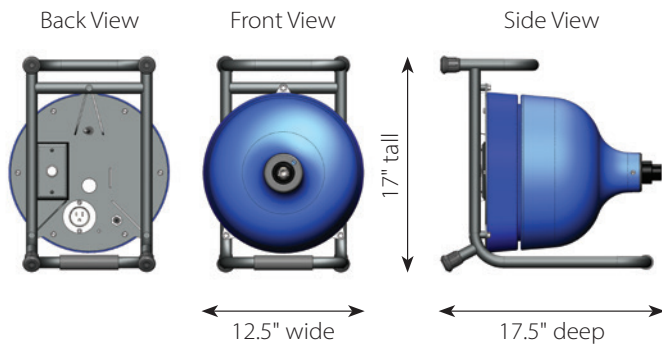

Learn more

See the M500 online at
mytana.com/product/m500

Elephant Trunk Guide Optional

A 3-foot trunk to help guide cable and protect home fixtures from cable scratches. Compatible with 1/4", 5/16" and 3/8" cable.

Attaches to M500 with quick connect fitting. *Also fits M661, requires hoop to attach.*



010324

(800) 328-8170
M-F | 7a to 5p CST

MyTana.com

EMAIL mytana@idexcorp.com



youtube.com/videoMyTana

MYTANA LLC 746 SELBY AVE • ST. PAUL, MN 55104